

REAR – AIR SPRING ASSEMBLY

Remove



WARNING: The air suspension system can be pressurized up to 10 bar (150 lb/in²). It's always important to make sure that dirt or grease doesn't enter system. Always wear hand, ear and eye protection when servicing the air suspension system.



WARNING: Do not inflate the air spring assembly unless it is supported on both ends by the vehicle frame and suspension system. Failure to observe this warning may result in serious injury and damage to the air springs assembly. **YOU SHOULD NEVER ATTEMPT TO DISMANTLE THE AIR SPRINGS.**

1. Raise the vehicle on a hoist or other adequate structure. **WARNING: Always support the vehicle on safety stands. Refer to your owner's manual for correct lifting instructions.** Remove road wheel.
2. Disconnect the pipe from top of air spring. Removing the air fitting will depressurize the air spring.
3. Seal off hose to prevent dirt or grease from entering system.
4. Remove the 2 clips securing the top of the air spring to chassis.
5. Collapse the air spring.
6. Rotate the air spring to unlock it from axle, and remove the old air spring from the vehicle.
7. Remove the old air connector from the pipe.

CAUTION: When refitting the new air spring, do not allow the vehicle to rest on the deflated air spring. The chassis must be supported until the new air spring is inflated.

Refit

1. Clean off the surface of air spring, axle, and chassis.
2. Refit the new air fitting to the pipe.
3. Install the new air spring onto the axle and rotate 90° to fully engage the lower bayonet fitting.
4. Refit the air pipe connector to air spring.
5. Fit road wheel and tighten nuts to 140Nm (103 lbs. ft).
6. Remove the support from under chassis and lower chassis onto the top of the air spring. **Resupport chassis with safety stands.**
7. Fit the clips to secure the top of the air spring to chassis. **Do not extend the suspension until you have re-inflated the new air spring!**
8. Remove all safety stands and slowly lower vehicle part way.



WARNING: DO NOT LOWER THE VEHICLE TO THE BUMP STOPS! Re-inflate air spring in small amounts, frequently stopping to make sure the air spring is rolled over the lower piston 360 degrees. Make sure the air springs' rubber bladder is rolled over the piston free of kinks or bends.

9. Re-inflate system and leak test air spring and connector with a soapy water solution.

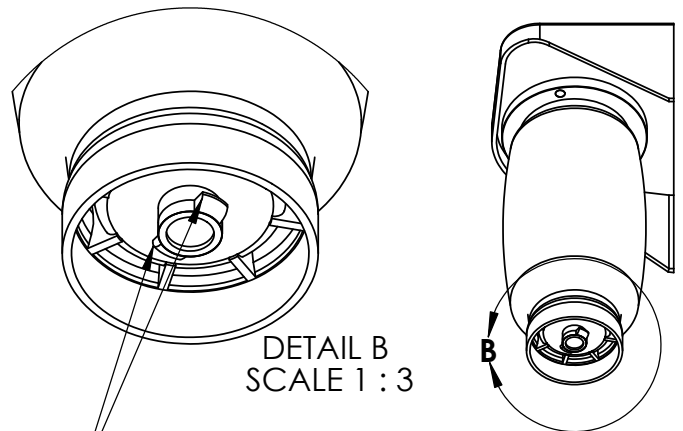
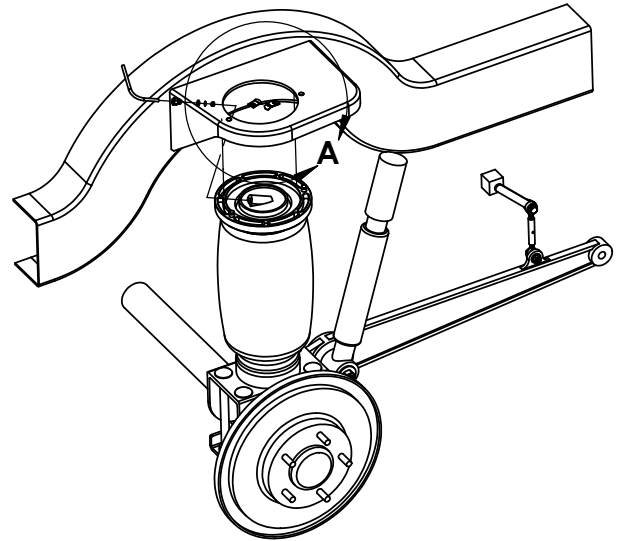
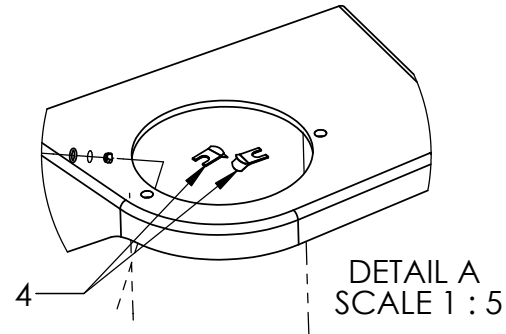

Do not extend the air spring until it has been correctly re-inflated. Failure to follow correct re-inflation instructions may cause bayonet clip to crack or break off.



PROPRIETARY AND CONFIDENTIAL
THE INFORMATION CONTAINED IN THIS DRAWING IS THE SOLE PROPERTY OF ARNOTT, INC. ANY REPRODUCTION IN PART OR AS A WHOLE WITHOUT THE WRITTEN PERMISSION OF ARNOTT, INC. IS PROHIBITED.

		DIMENSIONS ARE IN INCHES TOLERANCES: FRACTIONAL ± ANGULAR: MACH ± BEND ± TWO PLACE DECIMAL ± THREE PLACE DECIMAL ±	
		MATERIAL	
NEXT ASSY	USED ON	FINISH	
APPLICATION		DO NOT SCALE DRAWING	

	NAME	DATE
DRAWN	RLS	05/15/06
CHECKED		
ENG APPR.		
MFG APPR.		
Q.A.		
COMMENTS:		

DICOVERY 2 REAR SUSPENSION AIR SPRING - SLS		
SIZE A	DWG. NO. SLS	REV. 0
SCALE:1:16	WEIGHT:	SHEET 1 OF 1