



**MERCEDES BENZ E-CLASS / S-CLASS
AIR SUSPENSION COMPRESSOR
REPLACEMENT INSTRUCTIONS
KIT P-2192**



Congratulations on your selection to purchase an Arnott Air Suspension System. We at Arnott Air Suspension Systems are proud to offer a high quality product at the industries most competitive pricing. Thank you for your confidence in us and our product.

Proper installation is essential to experience and appreciate the benefits of this system. Please take a moment to review these installation instructions before you begin to install this system on your vehicle.

It is equally important to be aware of all necessary safety measures while installing your new Air Ride System. This includes proper lifting and immobilizing of the vehicle and isolation of any stored energy to prevent personal injury or property damage.

“Engineered to Ride, Built to last”



WARNING: The air suspension system is under pressure (up to 10 bar, or 150 lbf/in) verify pressure has been relieved and disconnect power to the air ride system prior to disassembly. Do not allow dirt or grease to enter the system. Always wear standard protective hand, ear, and eye protection when servicing the air suspension system.

Kit contains:

PARTS LIST		
P/N	QTY	DESCRIPTION
14-4263	1	COMPRESSOR



**MERCEDES BENZ E-CLASS / S-CLASS
AIR SUSPENSION COMPRESSOR
REPLACEMENT INSTRUCTIONS
KIT P-2192**

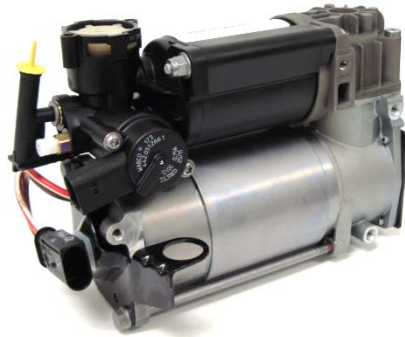

E-CLASS

Compressor Removal/Installation:

THE COMPRESSOR IS LOCATED ON THE VEHICLES DRIVERS SIDE BEHIND THE FRONT BUMPER.

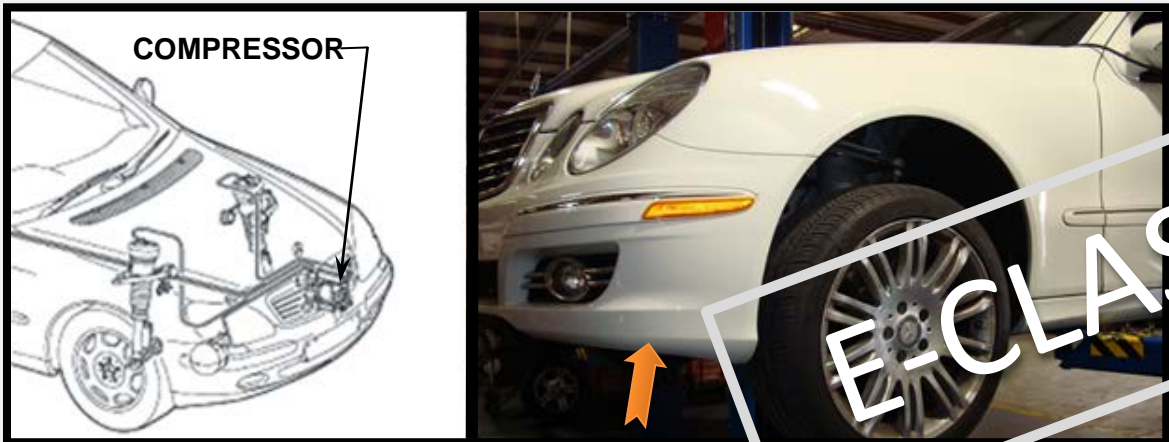

1.0 Disconnect battery (Ground lead). (figure 1.0)

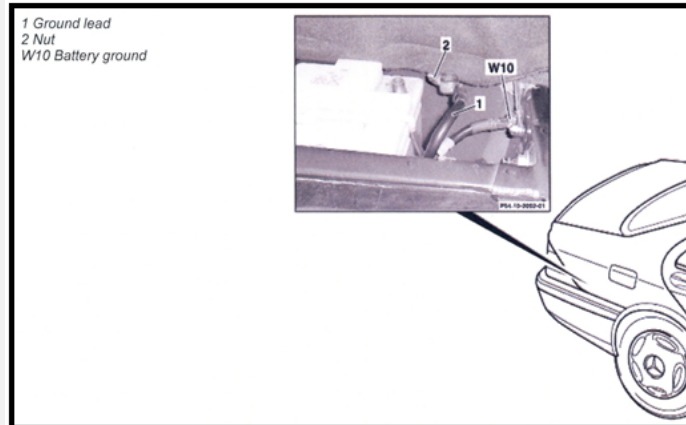

Figure 1.0

2.0 Remove engine compartment paneling. (Figure 2.0)

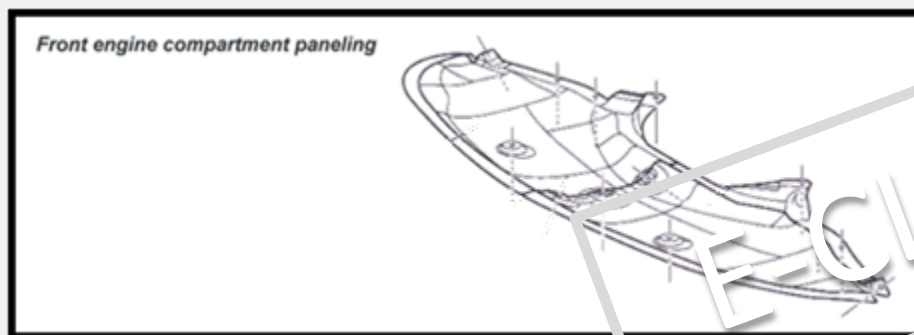

Figure 2.0

3.0 Unscrew pressure line connection and air filter line from the compressor unit. (Figure 3.0)

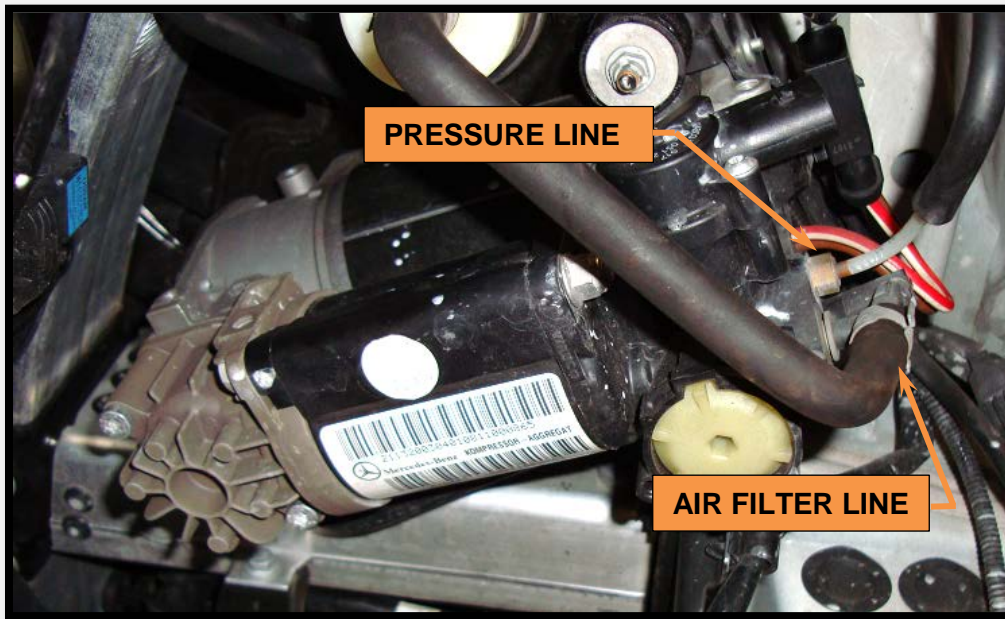

Figure 3.0

4.0 Disconnect the two (2) electrical connectors for the compressor unit (3). (Figure 4.0)

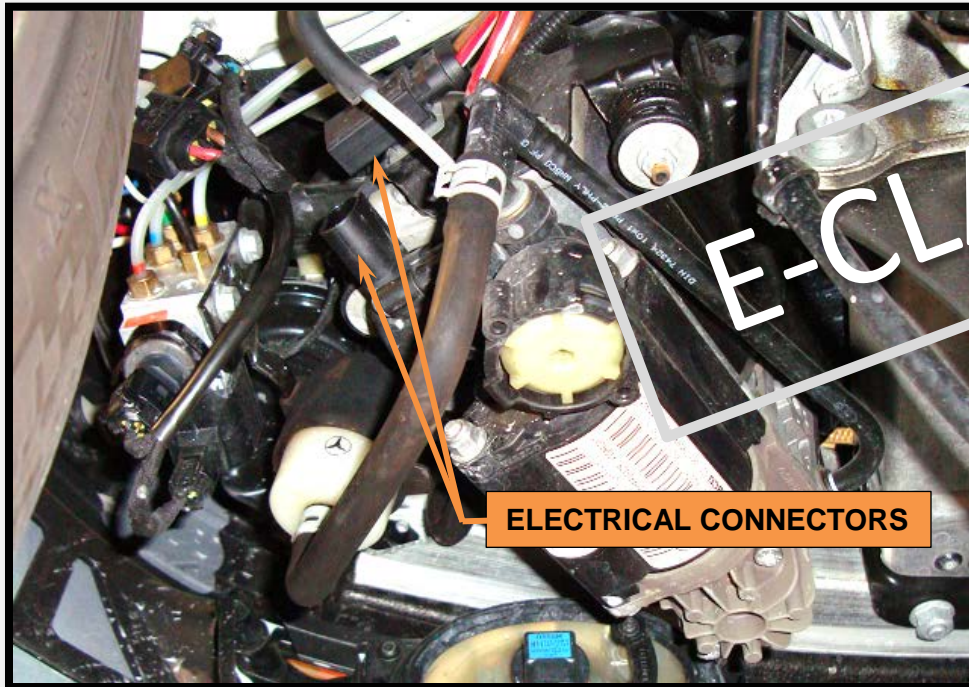

Figure 4.0

- 5.0 Unscrew the three nuts (arrows) and remove the compressor unit. When Re-installing torque to 3 Nm/ 2.2 Lb-ft. (Figure 5.0)

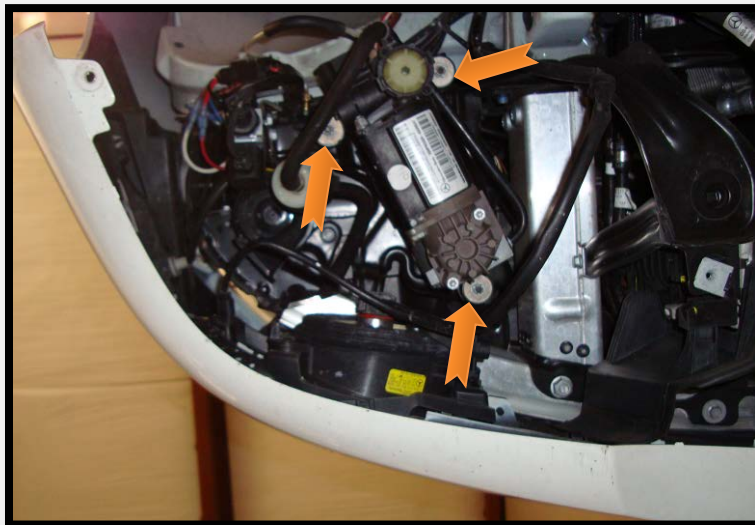

Figure 5.0

- 6.0 Removal Complete. Install in reverse order.
7.0 See (page 7) for isolator and line installation.



S-CLASS

Compressor Removal/Installation:

THE COMPRESSOR IS LOCATED ON THE VEHICLE'S PASSENGER SIDE BEHIND THE FRONT BUMPER.

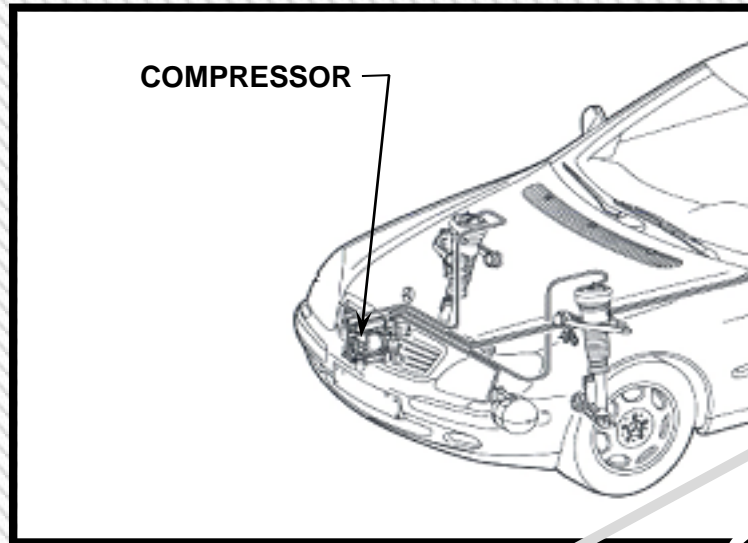

8.0 Disconnect battery (Ground lead). (figure 1.0)

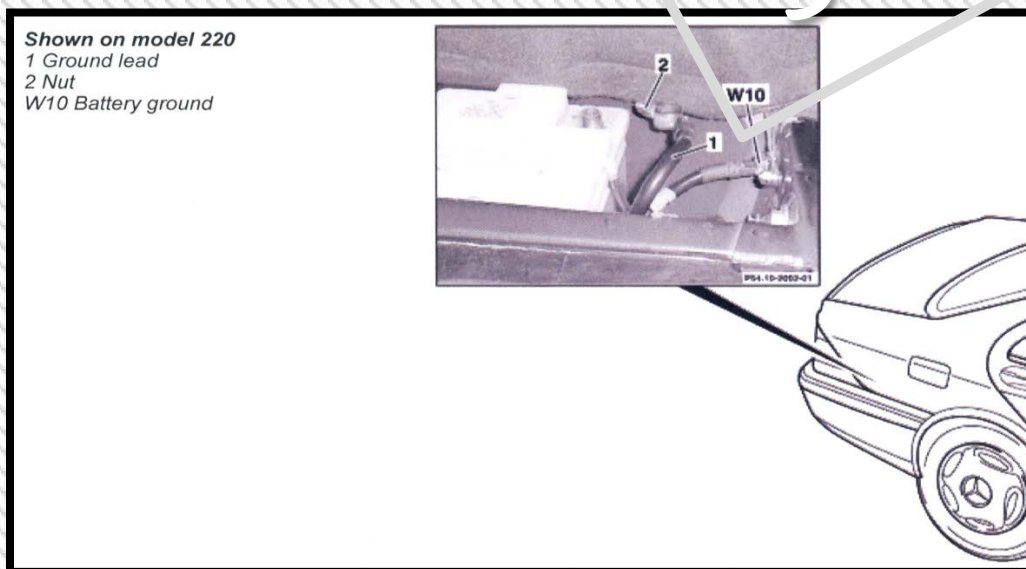

Figure 1.0

9.0 Remove engine compartment paneling (right front section only). (Figure 2.0)

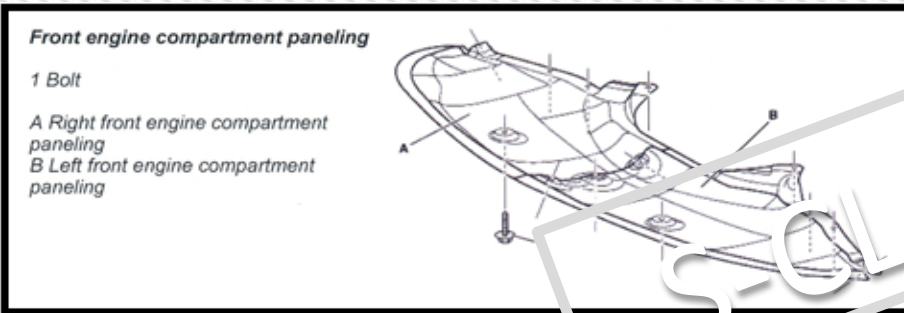

Figure 2.0

- 10.0 Unscrew pressure line connection (1) from the compressor unit (A9/1). (Figure 3.0)
- 11.0 Detach connector on the pressure valve (A9/1y1). (Figure 3.0)
- 12.0 Disconnect connector for air compressor motor (3). (Figure 3.0)
- 13.0 Pull intake hose air with filter (2) out of longitudinal member. (Figure 3.0)
- 14.0 Unscrew the three nuts (arrows) and remove the compressor unit (A9/1). When re-installing torque to 3 Nm/ 2.2 Lb-ft. (Figure 3.0)

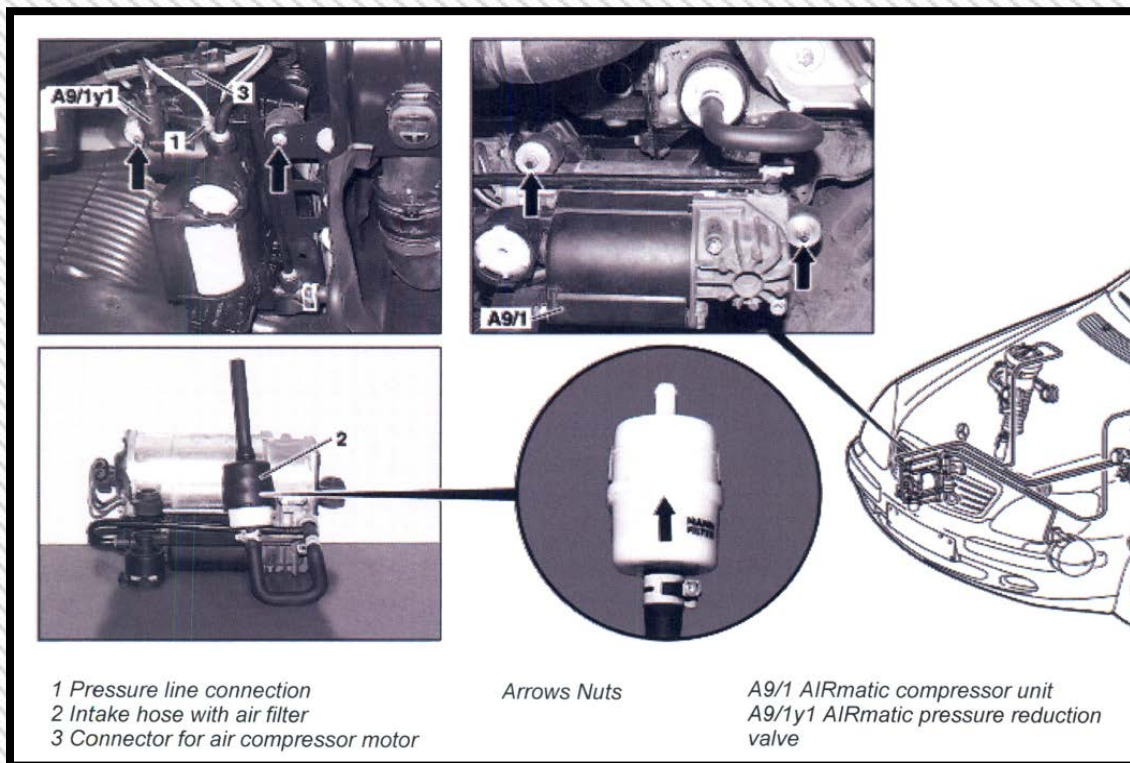

Figure 3.0

- 15.0 Removal Complete. Install in reverse order.
- 16.0 See (page 7) for isolator and line installation.



Prior to re-installing the new compressor unit:

- 1.0 You must first remove the three “vibration Isolator” from the old compressor and install them in the new compressor (note orientation of “vibration Isolator” feet when removing). (Figure 4.0)



Figure 4.0

BOTH

- 2.0 Remove the pressure line fitting from the pressure line (on vehicle) as shown:

- 2.1 Remove the pressure line from the fitting by removing the split ring collet and sliding the air fitting off the hose. (Figure 5.0)

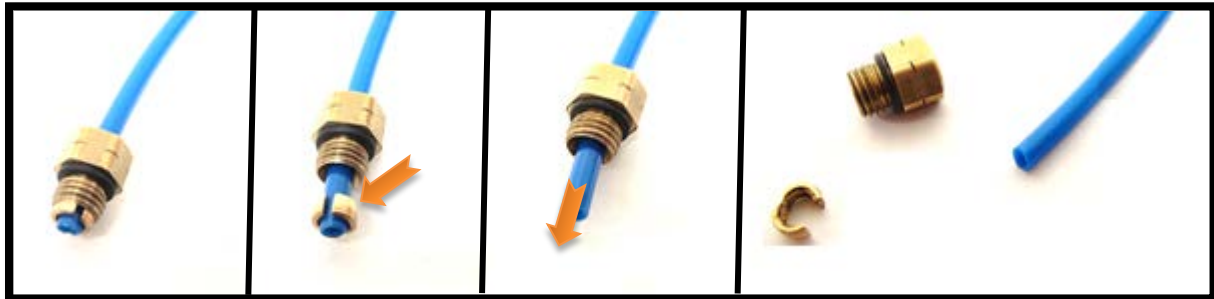
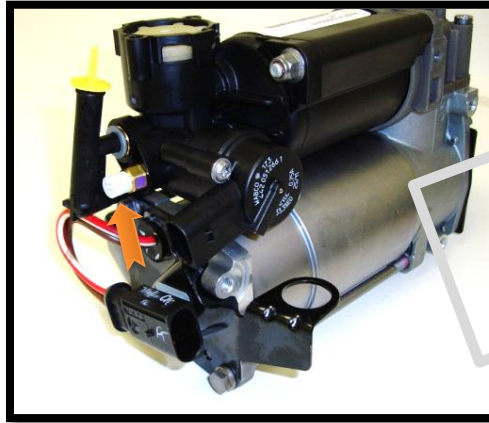

Figure 5.0

- 2.2 Remove plastic pin from new pressure line fitting. (Figure 6.0)



BOTH

Figure 6.0

- 2.3 Push pressure line into new fitting until it bottoms out; pull outward to verify hose is secure in pressure line fitting. (figure 7.0)

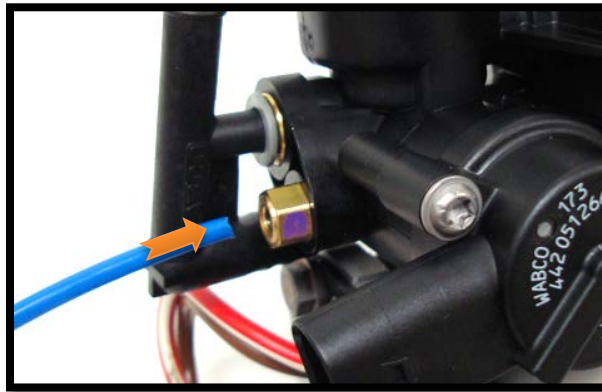

Figure 7.0